

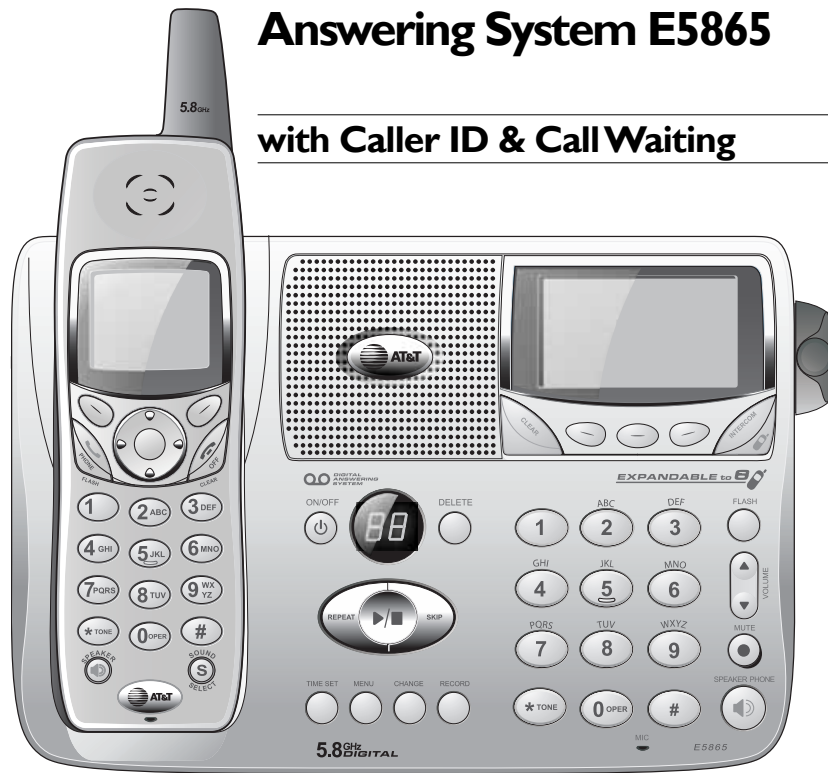

User Manual (Part 2)

5.8 GHz Cordless Speakerphone/ Answering System E5865

with Caller ID & Call Waiting



You must install and charge the battery before using the telephone

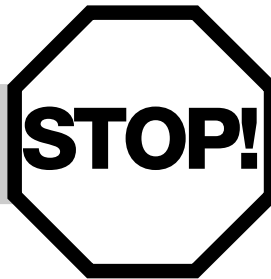

See page 7 for easy instructions

For customer service or product information, visit our web site at **www.telephones.att.com** or call **1-800-222-3111**

Please also read **Important Product Information** Enclosed in product package

Add new handsets to make your phone more versatile (see page 46)

Your telephone can accommodate up to 8 cordless handsets. You can add new handsets (sold separately) at any time. Up to 4 handsets at a time can be used.

The handset provided with your telephone is automatically registered as Handset 1. Additional handsets will be assigned numbers in the order they are registered (2, 3, 4, etc.) up to a maximum of 8 handsets.



Handset 1



Handset 2



Handset 3



User Manual (Part 2)
**5.8 GHz Cordless
 Speakerphone/
 Answering System
 E5865**



Table of contents

Getting Started

Quick reference guide2
 Parts checklist.....4
 Before you begin5
 Telephone base installation.....6
 Battery installation & charging7
 Wall mounting8
 Belt clip & optional headset.....9

Telephone Operation

Basic handset operation10
 Basic base operation11
 Options during calls12
 Intercom calls13
 Handset screen images.....14
 Handset sounds & alerts15
 Handset settings.....16
 Base settings.....17

Handset Phonebook Directory

New phonebook entries.....19
 Phonebook search.....20
 To dial, edit or delete entries.....21

Base Phonebook Directory

New phonebook entries.....23
 Phonebook search.....24
 To dial, edit or delete entries.....25

Handset Calls Log

To review voice messages27
 To review Caller ID log28
 To dial a Caller ID entry.....29
 To review redial log.....30

Base Caller ID & Redial

To review Caller ID log32
 To dial a Caller ID entry33
 To review redial log.....34

Answering System Operation

Answering system operation35
 Day and time announcements36
 Outgoing announcements.....37
 Announce Only mode38
 Changing feature options.....39
 Message playback40
 Recording and playing memos41
 Message window displays.....42
 Remote access.....43

Appendix

Display screen status icons.....44
 Alert tones & indicator lights.....45
 Adding new handsets46
 Charging spare batteries47
 In case of difficulty48
 INDEX.....50
 Technical specifications52
 Remote access wallet card53

Getting Started

Quick reference guide

Handset

Softkeys

Press a softkey to select a menu item displayed just above the key.

Phone/Flash

Press to begin a call, then dial a number.

During a call, press to receive an incoming call, if Call Waiting is activated (see page 12).

Speaker

Press to activate handset speaker-phone. Press again to switch call back to earpiece.

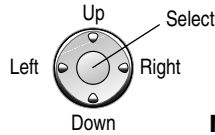

NavKey

Press center button to display menus. Press NavKey buttons to navigate through menus. Press center button to select menu item highlighted.

Off/Cancel

During a call, press to hang up.







While using menus, press to cancel an operation, back up to the previous menu, or exit the menu display.

Sound Select







Press to customize speaker sound for clear speakerphone conversations.









Main menu

- 
 Intercom
 See page 13
- 
 Directory
 See page 18
- 
 Calls Log
 See page 26
- 
 Pictures
 See page 14
- 
 Sounds&Alerts
 See page 15
- 
 Settings
 See page 16

Sounds & Alerts menu

 Vibrate	 Ringer Control	 Ringers
 Low Batt Tone	 Keypad Tone	 Range Tone

Settings menu

 Clock On/Off	 Set Time	 Contrast
 Phone Setup	 Language	 Reset Settings

Getting Started

Quick reference guide

Base/Speakerphone

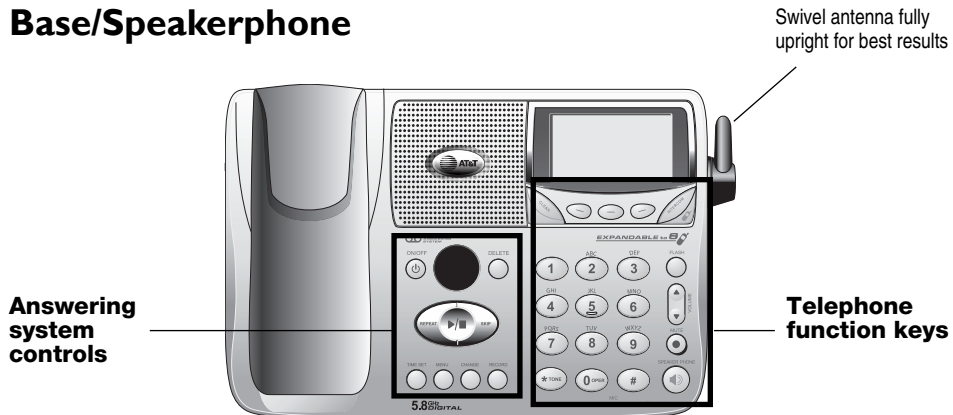

Telephone function keys (see pages 11-13)

- SOFTKEYS**Press to select menu item displayed just above the key
- CLEAR**Press to cancel an operation, back up to the previous menu, or exit the menu display
- INTERCOM**Press to transfer a call or initiate an intercom conversation
- FLASH**During a call, press to receive an incoming call, if Call Waiting is activated
- VOLUME**Press to adjust speakerphone listening volume
- MUTE**Press to silence microphone; press again to resume
- SPEAKERPHONE** ..Press to turn speakerphone on or off (begin or end a call)



Answering system controls (see pages 35-43)

- Press to repeat message. Press twice to hear previous message.
- Press to skip to next message.



Press to play or stop playing messages

- ON/OFF**Press to turn answering system on or off
- DELETE**Press to delete message currently playing
- TIME SET**Press to set the answering system clock
- MENU**Press to review or change answering system options
- CHANGE**Press to change a menu option
- RECORD**Press to record a memo or outgoing announcement

Getting Started

Parts checklist

Remember to save your sales receipt and original packaging in case you ever need to ship your telephone for warranty service. Check to make sure the telephone package includes the following:



Telephone base

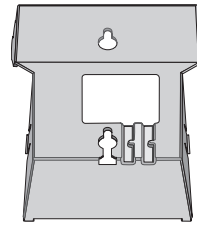

Wall mount bracket



Telephone handset

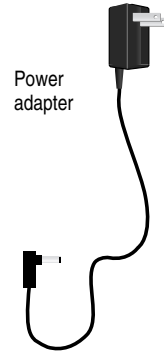

Power adapter



Batteries



Long telephone line cord



Short telephone line cord



Belt clip



Battery compartment cover

*Getting Started***Before you begin****About Caller Identification**

Caller ID with Call Waiting features in this telephone let you see who's calling before you answer the phone, even when you're on another call. These features require services provided by your local telephone company.

Contact your telephone service provider if:

- You have both Caller ID and Call Waiting, but as separate services (you may need combined service)
- You have only Caller ID service, or only Call Waiting service
- You don't subscribe to any Caller ID or Call Waiting services.

You can use this phone with regular Caller ID service, and you can use its other features without subscribing to either Caller ID or combined Caller ID with Call Waiting service. There may be fees for these services, and they may not be available in all areas.

Caller ID features will work only if both you and the caller are in areas offering Caller ID service, and if both telephone companies use compatible equipment.

See Caller ID Operation, beginning on page 28, for more details about how these features work.

Telephone operating range

This cordless telephone operates with the maximum power allowed by the Federal Communications Commission (FCC). Even so, this handset and base can communicate over only a certain distance — which can vary with the locations of the base and handset, the weather, and the construction of your home or office. For best performance, keep the base antenna fully upright.

If you receive a call while you are out of range, the handset might not ring — or if it does ring, the call might not connect when you press **PHONE**. Move closer to the base, then press **PHONE** to answer the call.

If you move out of range during a phone conversation, you might hear noise or interference. To improve reception, move closer to the base.

If you move out of range without pressing OFF, your phone will be left "off the hook." To hang up properly, walk back toward the telephone base, periodically pressing **OFF** until the call is disconnected.

Getting Started

Telephone base installation

Install the speakerphone base as shown below. Choose a location away from electronic equipment, such as personal computers, television sets or microwave ovens. Avoid excessive heat, cold, dust or moisture.

i **NOTE:** Use only the power cord supplied with this product. If you need a replacement, call 1 800 222-3111.

Be sure to use an electrical outlet not controlled by a wall switch.

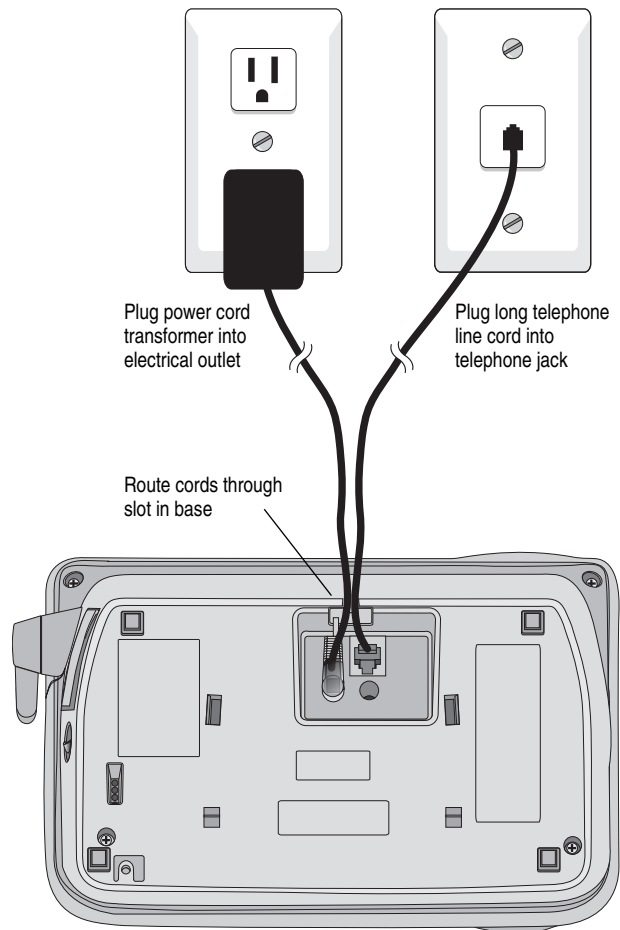

Getting Started

Battery installation & charging

After installation, place the handset in the base and allow batteries to charge for 12 hours before use. You can keep batteries charged by returning the handset to the base after each use. When battery power is fully depleted, a full recharge takes about 8 hours.

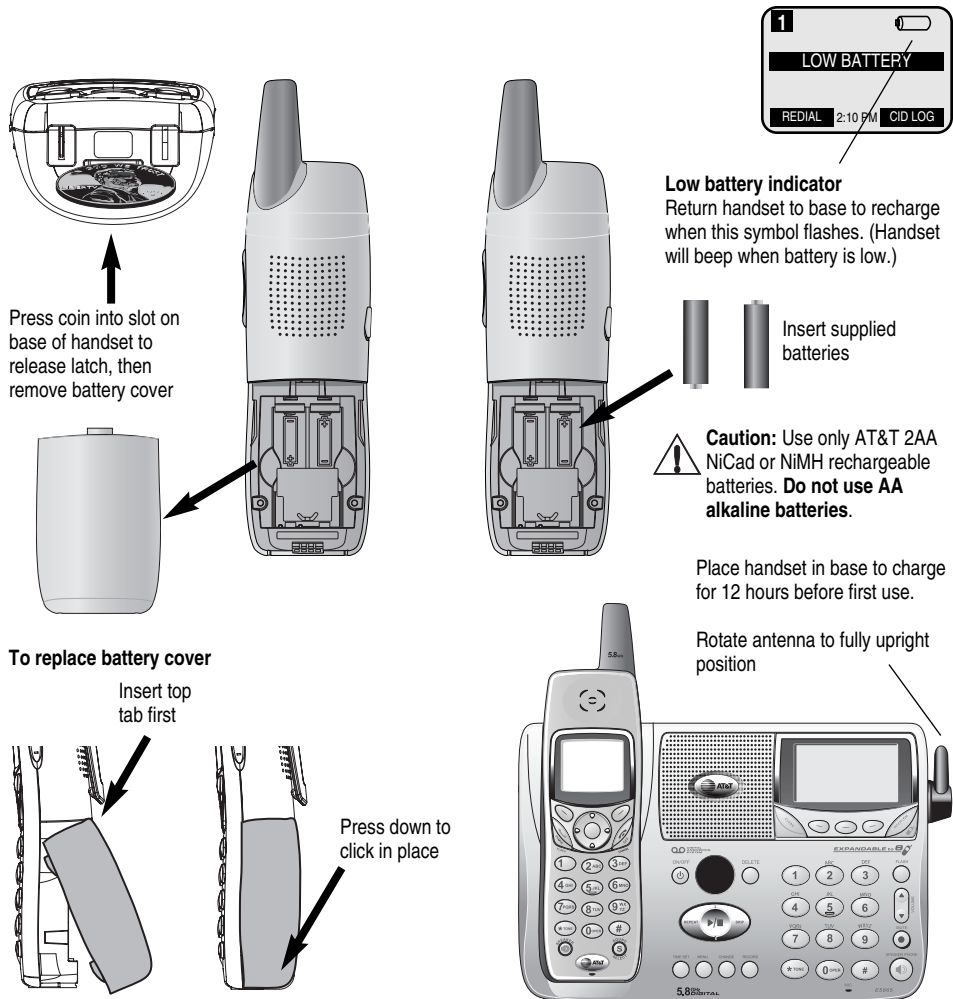

DID YOU KNOW?
Optional spare batteries can be kept charged in the base, for quick replacement when handset batteries become depleted (see page 47).

Getting Started

Wall mounting

The speakerphone base can be installed on any standard wall-phone outlet as shown below. Choose a location away from electronic equipment, such as personal computers, television sets or microwave ovens. Avoid excessive heat, cold, dust or moisture.

Connect cords as shown, then press and slide down firmly so base is held securely on outlet mounting pegs

Clip wall-mount bracket securely into notches on underside of base

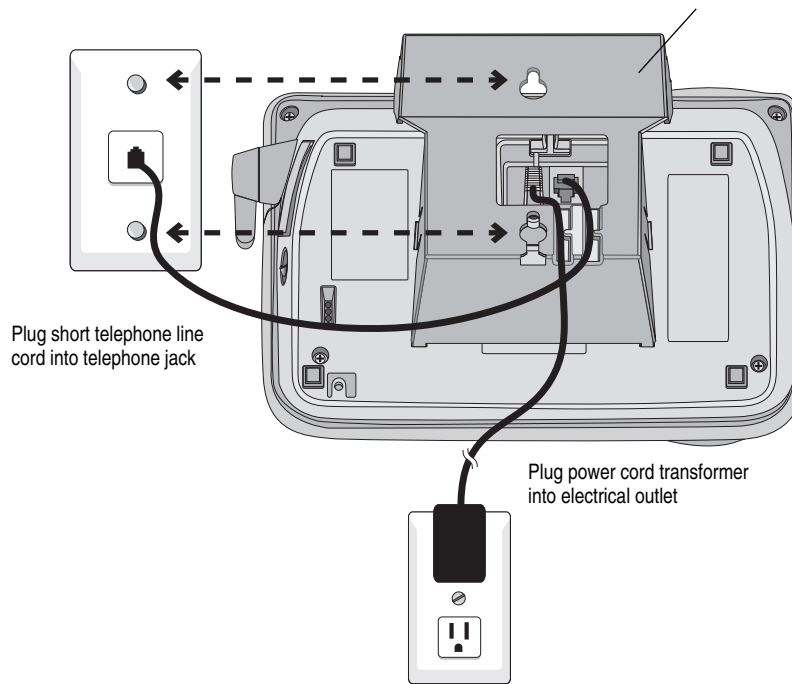

Rotate antenna to fully upright position

Getting Started

Belt clip & optional headset

Install belt clip as shown below if desired.

For hands-free telephone conversations, you can use any industry standard 2.5 mm headset (purchased separately). For best results use an AT&T 2.5 mm headset.

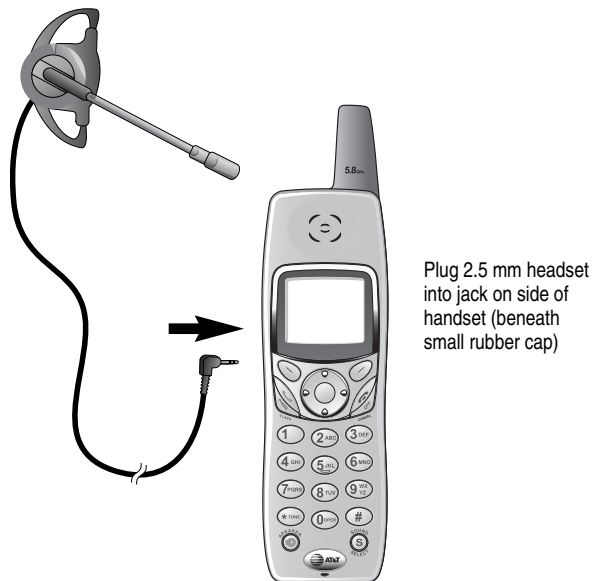
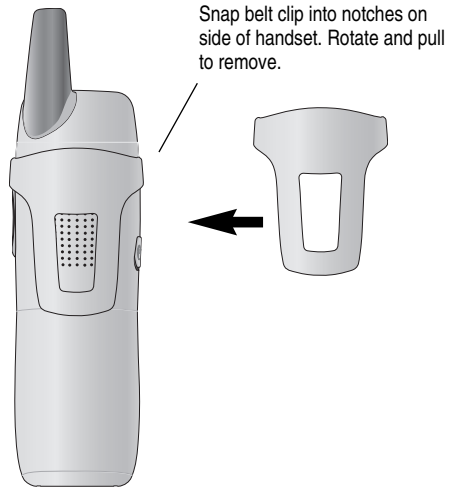

Telephone Operation

Basic handset operation



Making and answering calls

To answer a call, press **PHONE** or any dial pad key. To make a call, press **PHONE**, then dial a number. Press **OFF** to hang up.

To preview numbers before dialing, enter numbers first, then press **PHONE** to dial. Press the left NavKey to make corrections as you are entering numbers. Press **PAUSE** to add a 3-second dialing pause.

Hands-free speakerphone calls

To answer an incoming call, press **SPEAKER**. To make a call, press **SPEAKER**, then dial a number. During a call you can press **SPEAKER** to toggle between hands-free speakerphone and normal handset use. Press **OFF** to hang up.

Last number redial

Press **REDIAL** to display a list of numbers recently called. Use the NavKey control to select a number, then press **PHONE** to dial (see page 30 to delete the number, or copy it to your phonebook).

Hold and mute

Press **HOLD** to place a call on hold. Press **PHONE** to resume the call.

Press **MUTE** to silence the microphone. You will be able to hear, but your caller will not be able to hear you until you press **MUTE** again to resume speaking.

Call transfer

During a conversation you can transfer the call to the base speakerphone (or to another handset if you have more than one registered).

Press the middle NavKey button to display a list of sets. Press NavKey buttons to highlight the set you want, then press the middle NavKey button to transfer the call.

The call will be placed on hold. You can then press **PHONE** (or **SPEAKERPHONE** at the base) to resume speaking.

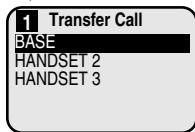
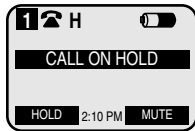

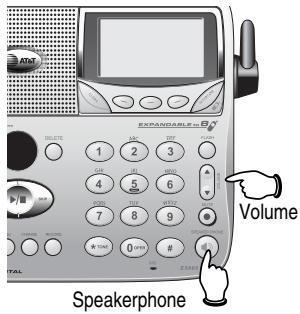

Telephone Operation

Basic base operation



Making and answering calls

To answer an incoming call, press **SPEAKERPHONE**. To make a call, press **SPEAKERPHONE**, then dial a number. Press **SPEAKERPHONE** again to hang up.

To preview numbers before dialing, enter numbers first, then press **SPEAKERPHONE** to dial. Press **CLEAR** at any time to make corrections as you are entering numbers. Press **PAUSE** to add a 3-second dialing pause.

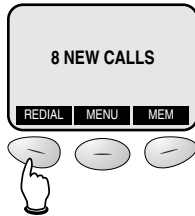

Last number redial

Press **REDIAL** to display a list of numbers recently called. Use the NavKey control to select a number, then press **SPEAKERPHONE** to dial (see page 34 to delete the number, or copy it to your phonebook).

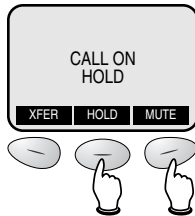

Hold and mute

Press **HOLD** to place a call on hold. Press **SPEAKERPHONE** to resume the call.

Press **MUTE** to silence the microphone. You will be able to hear, but your caller will not be able to hear you until you press **MUTE** again to resume speaking.

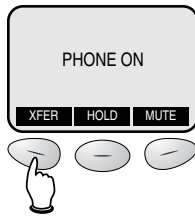

Call transfer

During a conversation you can transfer the call to a handset.

Press **XFER** to display a list of registered handsets. Use arrow buttons to highlight the set you want, then press **OK** to transfer the call.



The call will be placed on hold. You can then press **PHONE** or **SPEAKER** at the handset to resume speaking.

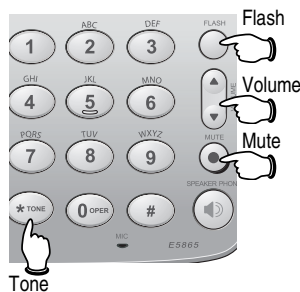
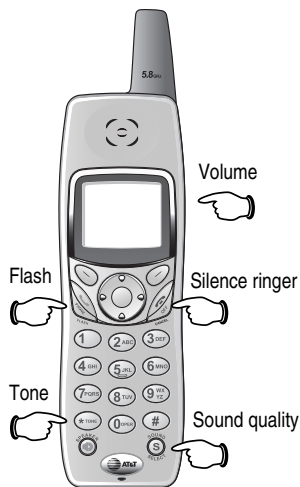

Telephone Operation

Options while on calls

To adjust volume or sound quality

Press **VOLUME** buttons on the handset or the base to adjust listening volume. Each button press raises or lowers volume by one level.

During a handset call you can press **SOUND SELECT** to change sound quality. You can choose Natural Audio, Bass Boost, Mid Boost or Treble Boost. Each button press changes to the next tone type.

Call waiting

If you have Call Waiting service, you will hear a beep if someone calls while you are already on a call. Press **FLASH** to put your current call on hold and take the new call. You can press **FLASH** at any time to switch back and forth between calls.

Ring silencing

Press **OFF** while the handset is ringing (or **MUTE** while the base is ringing) to silence the ringer. You can still answer, or let the caller leave a message.

3-way conference calls

During an outside call, you can use both the handset and base (or two local handsets) to allow a 3-way conversation.

While a call is in progress, others can press **PHONE** (or **SPEAKERPHONE** at the base) to join the conference call. Others can press **OFF** (or **SPEAKERPHONE** at the base) to drop out of the conference call, but the call will not be terminated until all sets hang up.

Temporary tone dialing

If you have dial pulse (rotary) service, you can switch to touch tone dialing during a call by pressing ***TONE***. This can be useful if you need to send tone signals for access to answering systems or long-distance services.

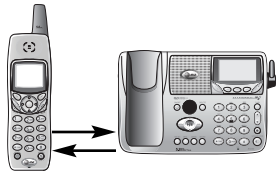

Display menu



Select Intercom

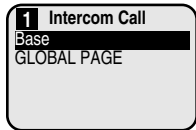

Press base Intercom button

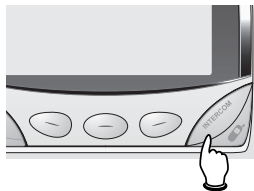

Telephone Operation

Intercom calls



Intercom calls

The intercom allows conversation between the handset and base, or between handsets if you have registered additional handsets for use with your system.

Use the NavKeys to select **INTERCOM** at the handset, or press the **INTERCOM** button on the base.

Press the **INTERCOM** button at a handset or at the base. Scroll down to select a station, or select **GLOBAL PAGE** to page all stations. Press the middle NavKey button (or **OK** at the base) to page the selected station.

At a handset, press **PHONE** to answer an intercom page. At the base, the phone will ring once, then answer the intercom page automatically.

When your intercom call is finished, press **OFF** at the handset (or **INTERCOM** at the base) to end the call.

Handling incoming calls

The phone will beep if you receive an outside call during an intercom conversation.

- At the handset, press **PHONE** to terminate the intercom call and answer the incoming call.
- At the base, press **INTERCOM** to terminate the intercom call, then press **SPEAKERPHONE** to answer the incoming call.

To allow the outside caller to join your intercom call, press **SPEAKERPHONE** without terminating the intercom call.

Telephone Operation

Handset screen images



This feature allows you to select an image or design as “wallpaper” to be displayed in the background of your handset display screen.

Press the middle NavKey button to display the menu, use navigation buttons to highlight **PICTURES**, then press the middle button again to select this option.

Choose a category (Images or Emotions), then use the NavKey buttons to display the available graphics. Press **SET** to select an image.

To remove an image from your screen, use the NavKey buttons to select **CLEAR WALLPAPER**, then press the middle NavKey button.



Display menu

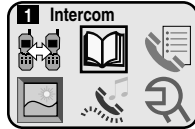

Select Pictures

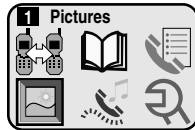

Choose category

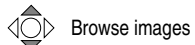
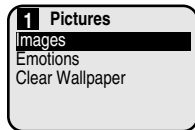

Browse images

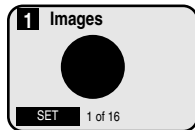

Press **SET** to select desired image



Options: On/Off



Volume Level: 1 to 5
Ringer: On/Off



Choose 1 of 14 ringer types



Options: On/Off



Options: On/Off



Options: On/Off

Telephone Operation

Handset sounds & alerts



Note: After selecting any option below, press the middle Navkey button to confirm your choice.

Vibrate (silent call alerting)

When on, the phone vibrates to signal an incoming call or intercom page. This can be useful in situations where ring tones are undesirable, or in noisy environments where ringing may not be heard. Changing the Vibrate setting does not affect the ringer.

Ringer control

At this menu you can set a default ring volume level (1-5), or turn the ringer off.

Ringers

This feature allows you to customize the incoming call alerter. The menu includes options for 8 ringer styles and 6 musical passages. You will hear an example of each ringing type as you scroll through the choices.

Low battery tone

The handset is factory programmed to alert you with a tone when the battery is low and needs recharging. You can turn this alert on or off at this menu.

Keypad tone

The handset is factory programmed to beep at each keypress. You can turn the keypad tones on or off at this menu.

Out-of-range tone

The handset is factory programmed to alert you with a tone when the handset is too far from the base, to remind you to move closer. You can turn this alert on or off at this menu.

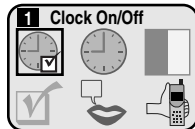
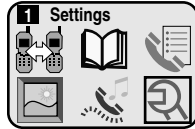

Turn clock display on/off

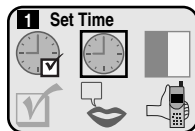

Set time

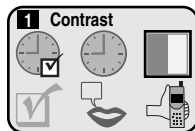

Adjust screen contrast



Enter base ID to register handset
Choose Tone or Pulse dialing

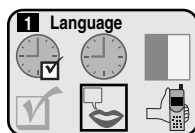

Choose screen display language

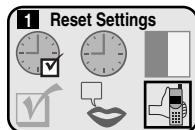

Clear phonebook
Restore factory default settings

Telephone Operation

Handset settings



Note: After selecting any option below, press the middle Navkey button to confirm your choice.

Clock On/Off

At this menu you can choose to turn the handset time display on or off.

Set time

Select this menu to set the time displayed on screen. You must enter four digits (09:23). Using the NavKey, press the **DOWN** button, then use **LEFT/RIGHT** buttons to set AM or PM. After you set the handset time once, it will thereafter be set automatically with incoming Caller ID information if you have this service (see page 5).

Contrast

At this menu you can adjust screen contrast to one of eight levels to maximize readability in different lighting conditions.

Phone setup

Choose this option to register a new handset or select dialing mode. To register, you must enter the 15-digit ID number of the base. (To find this number, go to the base, press **MENU**, scroll down to select **DISPLAY BASE ID**, then press **OK**.)

The phone is preset at the factory to use **TONE** dialing. You should change it to **PULSE** only if you do not have touch-tone dialing service.

Language

At this menu you can select the language used in all menus and screen displays. Choices are English, Español, Français.

Reset Settings

At this menu you can delete all entries from your handset phonebook, or restore all factory default settings.

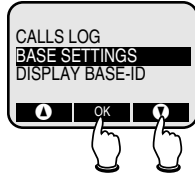

Set ringer volume (levels 1-6/Off)

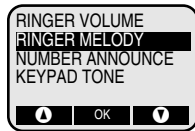

Set ringing style (8 choices)

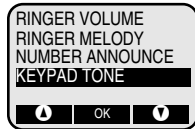

Options: on/off



Options: tone/pulse dialing



Set contrast (levels 1-16)



Options: English/Spanish/French

Telephone Operation

Base settings



Note: After selecting any option below, press the middle Navkey button to confirm your choice.

Ringer volume

At this menu you can set a default ring volume level (1-6), or turn off the ringer.

Ringer melody

This feature allows you to customize the incoming call alerter. The menu includes options for 8 ringing styles. You will hear an example of each ringing style as you scroll through the choices.

Number announce

If you have Caller ID service, you will hear a caller's telephone number spoken after the first ring. You can turn this feature on or off at this menu.

Keypad tone

The handset is factory programmed to beep at each keypress. You can turn the keypad tones on or off at this menu.

Tone/pulse

Factory default setting is **TONE**. Change this to **PULSE** only if you do not have touch-tone dialing service.

Contrast

At this menu you can adjust screen contrast to one of 16 levels to maximize readability in different lighting conditions.

Language

At this menu you can select the language used in all menus and screen displays. Choices are English, Spanish, French.



Handset Phonebook

Memory capacity

There are separate phonebook directories in the handset and the base. Each phonebook can store up to 50 entries. Each entry can contain a number up to 32 digits, and a name up to 16 letters long.

If you subscribe to Caller ID service from your local telephone company, you can select a picture to be displayed with each phonebook entry. You can also select a distinctive ringing type for each entry, so you know who is calling. A convenient search feature can help you find and dial numbers quickly (see page 20).

Timeouts and error tones

If you pause for too long while making an entry the Phonebook will time out and you will have to begin again.

If all memory locations are in use, an error tone will sound when you attempt to enter a new number. This means the memory is full, and you will not be able to store a new number until you delete an existing one.

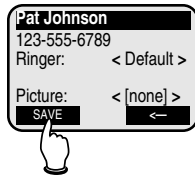
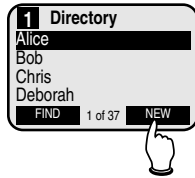

Press **SAVE** to complete entry, or down NavKey to customize entry with ringer or picture

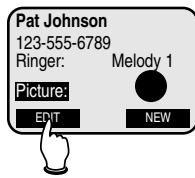
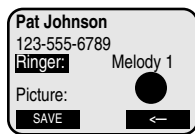
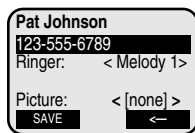

Handset Phonebook

New phonebook entries



To enter a name

Press dial pad buttons once for the first letter, twice for the second, three times for the third. Continue for lower-case letters. To enter a number, continue pressing the button until the number appears.

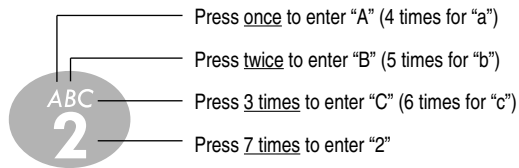

The cursor moves to the right when you press another dial pad button or the **RIGHT** NavKey button (press twice to enter a space). When the name is complete, press **OK**.

- Press the <-- button to erase letters if you make a mistake.
- Press **1** repeatedly to enter an ampersand (&), apostrophe ('), comma (,), period (.), or numeral (1).

To enter a number

Use the dial pad to enter up to 32 digits. When the number is complete, press **OK**.

- Press the <-- button to erase numbers if you make a mistake.
- To enter a 3-second dialing pause, press and hold **#** until "P" appears.

Customizing entries

Press the **DOWN** NavKey button, then **LEFT** or **RIGHT** to choose a distinctive **RINGER** (see page 15). If you have Caller ID service, the ringer you assign will alert you when this person calls.

Press the **DOWN** NavKey button, then **LEFT** or **RIGHT** to insert a **PICTURE** into this entry (see page 14).

Press **SAVE** to save your new entry (or press **CANCEL** to discard changes and exit).

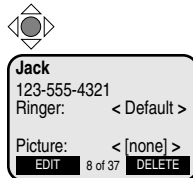
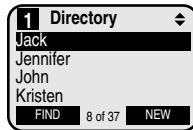
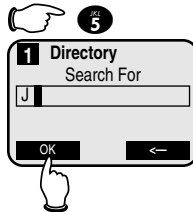
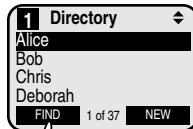
 Select Directory

Handset Phonebook

Phonebook search



You can use the NavKey buttons to browse through the phonebook, or search to find a specific entry. You can press **CANCEL** at any time to exit the directory.

To browse through the directory

To browse, press **UP** or **DOWN** NavKey buttons to scroll through all entries one by one.

To search alphabetically

To shorten your search, press **FIND**, then use the telephone dial pad to enter the first letter of a name. When you press **OK**, the first name beginning with that letter will be displayed.

Press dial pad buttons once for the first letter, twice for the second, three times for the third, as shown on the previous page.

For example, press **5 (JKL)** once to find Jack, twice to find Kristen, or three times to find Linda.

To call a displayed number

When you find the entry you want, press **PHONE** (or **SPEAKER**) to dial.

To modify the entry, press the middle NavKey button, then select **EDIT** (see next page).

Select Directory

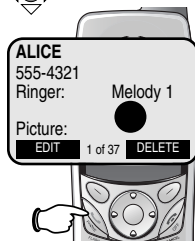
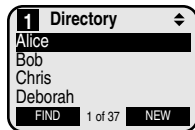

Press **PHONE** to dial entry

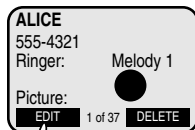

Press **EDIT** to change entry

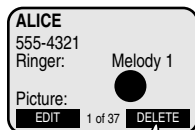

Press **DELETE** to delete entry

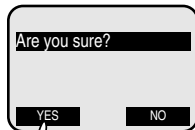

Press **YES** to confirm

Handset Phonebook

To dial, edit or delete entries



To edit a listing

When any phonebook entry is displayed, press **EDIT** to modify the entry. You can change the name, number, distinct ringer setting or picture by following the steps on page 19.

To dial a number

Press **PHONE** (or **SPEAKER**) to dial the displayed number.

To delete an entry

Press **DELETE** to delete the displayed entry from the phonebook. Press **YES** to confirm. Press **NO** to return to previous display. Once deleted an entry cannot be recovered.

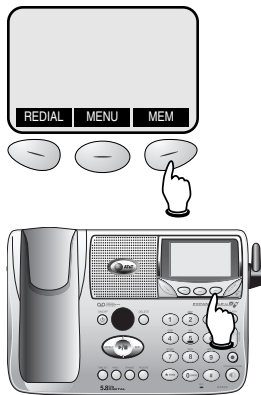

Base Phonebook

Memory capacity

There are separate phonebook directories in the handset and the base. Each phonebook can store up to 50 entries. Each entry can contain a number up to 32 digits, and a name up to 16 letters long. A convenient search feature can help you find and dial numbers quickly (see page 24).

Timeouts and error tones

If you pause for too long while making an entry, the Phonebook will time out and you will have to begin again.

If all memory locations are in use, an error tone will sound when you attempt to enter a new number. This means the memory is full, and you will not be able to store a new number until you delete an existing one.

Enter number, then press **MEM**

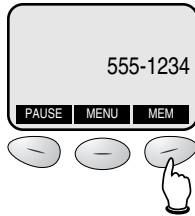

Enter name, then press **SAVE**

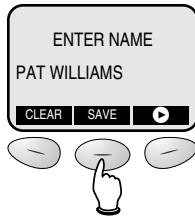

Base Phonebook

New phonebook entries



To enter a number

Use the dial pad to enter up to 32 digits. When the number is complete, press **MEM**.

- Press **CLEAR** to erase numbers if you make a mistake.
- Press **PAUSE** to enter a 3-second dialing pause.

To enter a name

Press dial pad buttons once for the first letter, twice for the second, three times for the third. Continue for lower-case letters. To enter a number, continue pressing the button until the number appears.

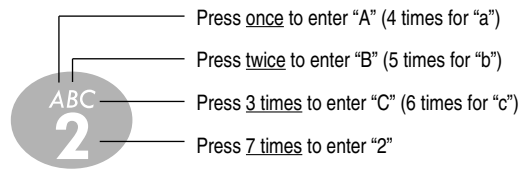

The cursor moves to the right when you press another dial pad button or the **▶** button. Press **▶** twice to enter a space.

- Press **CLEAR** to erase letters if you make a mistake.
- Press **1** repeatedly to enter an ampersand (&), apostrophe ('), comma (,), period (.), or numeral (1).

Storing the entry

Press **SAVE** to store your new phonebook entry. To change it later, see page 25.

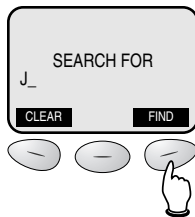
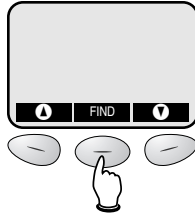
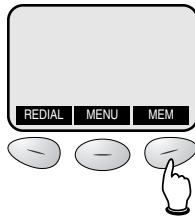

Use up/down arrow keys to search for next/previous names

Base Phonebook

Phonebook search



You can use the **▲** **▼** buttons to browse through the phonebook, or search to find a specific entry. Press and hold **CLEAR** at any time to exit the directory.

To browse through the directory

To browse, press **▲** or **▼** to scroll through all entries one by one.

To search alphabetically

To shorten your search, press **FIND**, then use the telephone dial pad to enter the first letter of a name. When you press **FIND** again, the first name beginning with that letter will be displayed.

Press dial pad buttons once for the first letter, twice for the second, three times for the third, as shown on the previous page.

For example, press **5 (JKL)** once to find Jack, twice to find Kevin, or three times to find Linda.

To call a displayed number

When you find the entry you want, press **SPEAKERPHONE** to dial. Or press **EDIT** to modify the entry (see next page).

Base Phonebook

To dial, edit or delete entries



To edit a listing

When any phonebook entry is displayed, press **EDIT**. At the next screen, press **EDIT** again, then choose **NAME** or **NUMBER**. You can change the name or number by following the steps on page 23.

To dial a number

Press **SPEAKERPHONE** to dial the displayed number.

To delete an entry

At the Edit menu, press **DEL** to display options:

- To delete only the displayed entry, press **THIS**.
- To delete all entries in the phonebook, press **ALL**. To confirm your choice, press **YES** at the confirmation screen, and all entries will be deleted.

Once deleted, entries cannot be recovered.

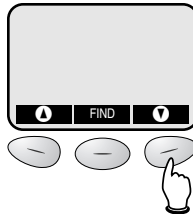
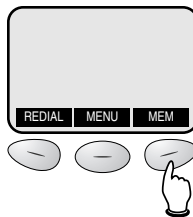

Press **SPEAKERPHONE** to dial entry



Press **EDIT** to modify or delete



Press **DEL** to delete entry
 Press **EDIT** to change entry
 Press **NAME** to change name
 Press **NUMBER** to change number

Handset Calls Log



The Calls Log keeps track of calls you've made and received, and even lets you check voice messages from your handset.

Use the NavKey controls to select Calls Log, then make a selection from the list displayed:

Review Messages (see next page)

Play or delete voice messages.

Review CID Log (see page 28)

If you have Caller ID service, you can review the CID Log to find out who has called, return the call without dialing, or transfer the caller's name and number into your phone directory.

Clear CID Log (see page 28)

Use this command to delete all entries in your Caller ID Log.

Review Redial (see page 30)

This screen shows a list of the most recent 10 numbers you've dialed. You can redial any number, delete it from the redial log, or copy it to your phonebook.

Clear Redial (see page 30)

Use this command to delete all recently called numbers from your Redial list.

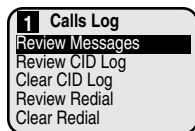
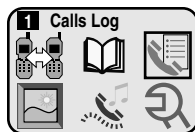

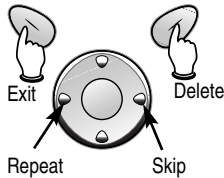
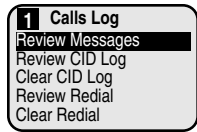

The screen alerts you when you have new messages. Press **MSGS** to hear them.

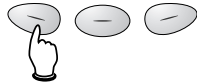

Handset Calls Log

Review voice messages



At this menu you can use your handset to hear your memos, or voice messages callers have left in your base answering system (see pages 35-43).

Playback options

At the Messages screen, use the NavKey to control message playback:

- Press the **LEFT** NavKey to repeat the message currently playing. Press twice to hear previous message.
- Press the **RIGHT** NavKey to skip forward to the next message.

At the handset, voice messages are played through the speakerphone. If you prefer to listen privately, you can press **SPEAKER** to switch to earpiece playback.

To delete a message, press **DELETE** while the message is playing.

Press **EXIT** to halt playback and exit the Messages menu.

Announcements

- When playback begins, you will hear the total number of messages.
- Before each message, you will hear the day and time it was received.
- After the last message, you will hear "End of messages."

Handset Calls Log

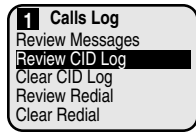

Save entry in phonebook



Delete entry

Display previous entry



Display next entry

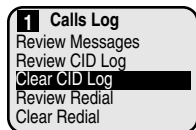

To review your call log



How Caller ID works

If you subscribe to Caller ID service, information about each caller will be displayed after the first ring.

You can review the log to find out who has called, return the call without dialing, or transfer the caller's name and number into your phonebook.

The call log can store up to 50 entries. Calls are displayed in reverse order (most recent first). When the log is full, the oldest entry is deleted to make room for new incoming call information.

If you answer a call before the information appears on the screen, it will not be saved in your call log.

Names of callers are displayed only if the information is provided by your local telephone company. If the telephone number of the person calling matches a number in your phonebook, the name shown on screen will match the name you entered into your phonebook. (Example: If "Christine Smith" calls, her name will appear as "Chris" if this is how you entered it.)

To review your Caller ID log

The most recent call is displayed first. Use the NavKey buttons to scroll through the list as shown at left.

To return a call

Press **PHONE** (or **SPEAKER**) to call the person currently displayed (see page 29 for important dialing options).

To save or delete an entry

Press **SAVE** to copy the displayed information into your phonebook (see page 19). Press **DELETE** to delete this entry from your CID log.

To delete all entries

To clear the Caller ID log of all entries, return to the Calls Log menu, then use the NavKey controls to scroll down and select **CLEAR CID LOG**. To confirm, press **YES**.

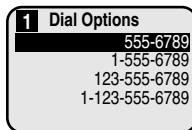

Select desired option,
then press to dial

Handset Calls Log

To dial a call log entry



When any Caller ID screen is displayed, press **PHONE** (or **SPEAKER**) to dial the number exactly as it appears on the screen.

Dialing options

Caller ID numbers may appear with an area code that may not be required for local calls. If the number displayed is not in the correct format, you can change how it is dialed.

Press the middle NavKey button to see a list of dialing options. Press the **UP** or **DOWN** NavKey buttons to select the option you want. To dial it, press the middle NavKey button again.

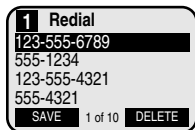
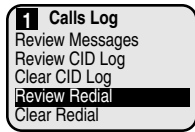
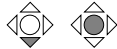

Save entry in phonebook



Delete entry

Display previous entry



Display next entry

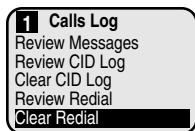

Handset Calls Log

To review your redial log



About the redial memory

You can review the redial log to see what numbers you've recently called, redial, or copy the number into your phonebook.

The handset remembers the last 10 numbers you call. Each time you make a call the oldest entry is deleted to make room for a new one.

To review your redial log

The most recent call is displayed first. Use the **UP/DOWN** NavKey buttons to scroll through the list as shown at left.

To redial a call

Press **PHONE** (or **SPEAKER**) to redial the number currently displayed.

To save or delete an entry

Press **SAVE** to copy the highlighted number into your phonebook (see page 19).

Press **DELETE** to delete this entry from your redial log.

To delete all entries

To clear the redial log of all entries, return to the Calls Log menu, then use the **DOWN** NavKey button to scroll down and select **CLEAR REDIAL**. To confirm, press **YES**.

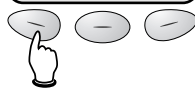
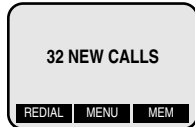

Display redial log

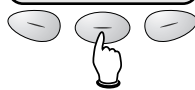
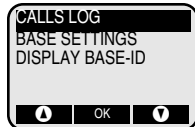
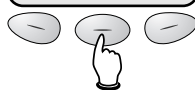
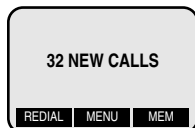

Display calls log

Base CID & Redial

The memory in the telephone base keeps track of calls you've made and received. Use the softkeys beneath the display screen to select **REDIAL** (for a list of outgoing calls) or **MENU**, then **CALLS LOG** (for a list of incoming calls).

Calls Log (see page 32)

If you have Caller ID service, you can review the Calls Log to find out who has called, return the call without dialing, or transfer the caller's name and number into your phone directory.

Review Redial (see page 34)

This screen shows a list of the most recent 10 numbers you've dialed. You can call the number again without dialing, or copy the number into your phone directory.

Base Calls Log & Redial

To review your call log



How Caller ID works

If you subscribe to Caller ID service, information about each caller will be displayed after the first ring.

You can review the log to find out who has called, return the call without dialing, or transfer the caller's name and number into your phonebook.

The call log can store up to 50 entries. Calls are displayed in reverse order (most recent first). When the log is full, the oldest entry is deleted to make room for new incoming call information.

If you answer a call before the information appears on the screen, it will not be saved in your call log.

Names of callers are displayed only if the information is provided by your local telephone company. If the telephone number of the person calling matches a number in your phonebook, the name shown on screen will match the name you entered into your phonebook. (Example: If "Christine Smith" calls, her name will appear as "Chris" if this is how you entered it.)

To review your call log

The most recent call is displayed first. Use the arrow buttons to scroll through the list as shown at left.

To return a call

Press **SPEAKERPHONE** to call the person currently displayed (see page 33 for important dialing options).

To save or delete an entry

Press **SAVE** to copy the displayed information into your phonebook (see page 23).

Press **DEL** to choose an option. Select **THIS** to delete the entry displayed, or **ALL** to clear the Caller ID log of all entries (to confirm, press **YES**).

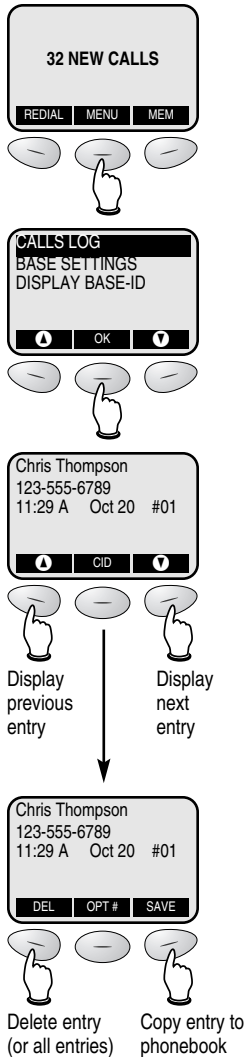

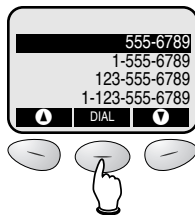
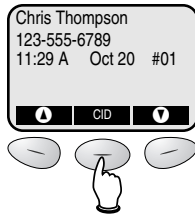

Select desired option,
then press to dial

Base Calls Log & Redial

To dial a call log entry



When any Caller ID screen is displayed, press **SPEAKERPHONE** to dial the number exactly as it appears on the screen.

Dialing options

Caller ID numbers may appear with an area code that may not be required for local calls. If the number displayed is not in the correct format, you can change how it is dialed.

Select **CID**, then **OPT #** to see a list of dialing options. Press **▼** or **▲** to highlight the option you want, then press **DIAL**.

Base Calls Log & Redial

To review your redial log



About the redial memory

You can review the redial log to see what numbers you've recently called, redial, or copy the number into your phonebook.

The handset remembers the last 10 numbers you call. Each time you make a call the oldest entry is deleted to make room for a new one.

To review your redial log

The most recent call is displayed first. Use the arrow keys to scroll through the list as shown at left.

To redial a call

Press **SPEAKERPHONE** to redial the number currently displayed.

To save or delete an entry

Press **SAVE** to copy the highlighted number into your phonebook (see page 23).

Press **ERASE** to delete this entry from your redial log.

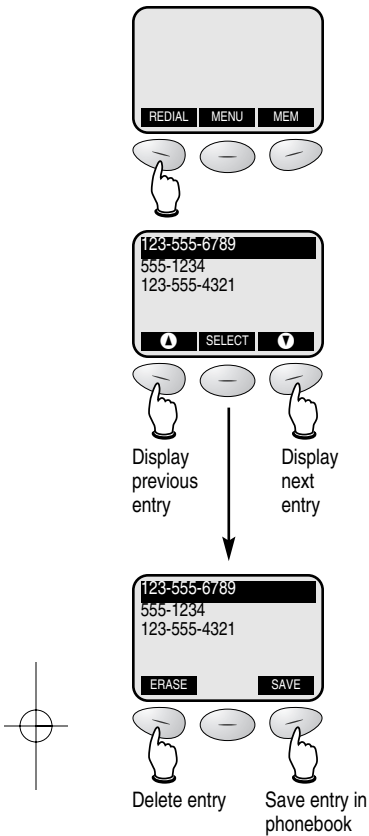



Message counter

Number of messages waiting (or, during playback, message number currently playing)



Answering System Operation

Message capacity

The answering system can record up to 99 messages, depending on how long each message is. Individual messages can be up to 4 minutes long, but total maximum recording time is 25 minutes. Messages will remain available for replay until you delete them.

Handset access

In addition to the features described in this section, you can also use your handset to review or delete messages (see page 27).

Press to start or stop message playback (see page 40)

Press to turn answering system on or off

Press to delete message (see page 40)

Press to repeat message; hold to slow playback (see page 40)

Press to skip message; hold to speed up playback (see page 40)

Press to set clock (see page 36)

Press to record memo (see page 41) or outgoing announcement (page 37)

Press repeatedly to hear feature options (see page 39)

Press to select or change a feature option (see page 39)



Answering System Operation

Day and time announcements

To set day and time

Before playing each message, the answering system announces the day and time the message was received.

Before using the answering system, you should follow the steps at left to set the day and time, so messages are dated correctly.

The system uses voice prompts to guide you. Each time you press **CHANGE**, the day, hour, minute or year advances by one. When you hear the correct setting, press **TIME SET** to move to the next setting.

To check day and time

You can press **TIME SET** at any time to hear the current day and time without changing it.

- 1** **TIME SET**
 "Friday, 10:07 am, 2003"
"To change clock, press Time Set"
- 2** **TIME SET**
 "Friday"
- 3** **CHANGE**
 "Monday"
 Press until correct day is spoken
- 4** **TIME SET**
 "10 am"
- 5** **CHANGE**
 "2 pm"
 Press until correct hour is spoken
- 6** **TIME SET**
 "07"
- 7** **CHANGE**
 "26"
 Press until correct minute is spoken
- 8** **TIME SET**
 "2003"
- 9** **CHANGE**
 "2004"
 Press until correct year is spoken
- 10** **TIME SET**
 "Monday, 2:26 pm, 2004"

NOTE: Press and hold **CHANGE** to advance the minute or year by 10.

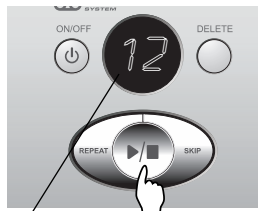

Elapsed recording time (seconds) Press to stop recording

1 **MENU**

“Change announcement”

2 **(Play/Stop)**

(Plays announcement previously recorded)

Or

2 **RECORD**

“Now recording...”

3 Speak into microphone



Microphone ↑

4 **(Play/Stop)**

(Announcement is played back)

Answering System Operation

Outgoing announcements

Outgoing announcements are the messages callers hear when calls are answered by the answering system.

The phone is pre-programmed with an announcement that answers calls with **“Hello. Please leave a message after the tone.”** You can use this announcement, or replace it with a recording of your own voice.

To record your outgoing announcement

Press **MENU** until you hear “Change announcement.” Then press **RECORD** and begin speaking after you hear “Now recording.” Speak facing the telephone base from about 9 inches away.

Elapsed time (in seconds) will be shown in the message window as you record. You can record an announcement up to 90 seconds long. Announcements less than 3 seconds long will not be recorded.

To delete your outgoing announcement

Press **MENU** until you hear “Change announcement,” then press **PLAY/STOP** to begin playback. Press **DELETE** during playback to delete your announcement.

When your announcement is deleted, calls will be answered with the pre-programmed announcement described above.



"A" is displayed when Announce Only is activated

- 1 **MENU**
 "Change Announce Only"
- 2 **CHANGE**
 "Off"
- 3 **CHANGE**
 "On"
- 4 **(Play/Stop)**
Beep
 (Option selected)

Answering System Operation

Announce Only mode

In Announce Only mode, callers hear an announcement but cannot leave messages. This option is useful, for example, to notify callers that you will be away for an extended period and request that they call back after a certain date.

To turn Announce Only on or off

Press **MENU** repeatedly until you hear "Change Announce Only." Then press **CHANGE** until you hear the option you want (On or Off). Press **PLAY/STOP** to store your selection and exit, or press **MENU** again to modify other features (see page 39).

To record your outgoing announcement

When Announce Only is turned on, calls are answered with a pre-recorded announcement that says **"We're sorry, messages to this number cannot be accepted."** You can use this announcement, or replace it with a recording of your own voice.

After turning on the Announce Only feature, follow the steps on page 37 to record your announcement. Callers will hear this announcement only when the Announce Only feature is turned on. Otherwise they will hear the standard announcement asking them to leave a message.

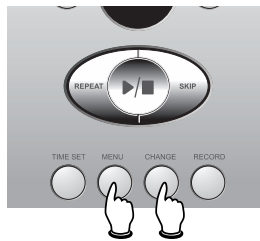

1  **MENU**

Press until desired feature is heard (see list at right)

2  **CHANGE**

Press until desired selection is heard

3  **MENU**

Press to set selection and **move** to next menu option

Or

  **(Play/Stop)**

Press to set selection and **exit** menu

Answering System Operation

Changing feature options

Menu features can be changed to customize how the answering system operates. Press **MENU** repeatedly to hear each feature. Press **CHANGE** when you hear the feature you want to modify.

Feature options (Default settings underlined>



System announces:	Feature description:
"Change Announcement" Options: [record announcement]	Record your outgoing announcement (see page 37).
"Change remote access code" Options: [enter 2-digit code] <u>19</u>	Enter a 2-digit number (10-99) for remote access from another phone (see page 43).
"Change message alert" Options: On / <u>Off</u>	When on, the telephone beeps every 10 seconds when you have new messages.
"Change announce only" Options: On / <u>Off</u>	When on, callers hear an announcement but cannot leave messages (see page 38).
"Change call screening" Options: <u>On</u> / Off	When on, you can hear callers leave messages, or answer the call.
"Change number of rings" Options: 2 / <u>4</u> / 6 / Toll Saver	Choose number of rings before the system answers a call. When Toll Saver is active, the system answers after 2 rings if you have new messages, and after 4 rings if you have no new messages.

 **NOTE:** Press and hold **CHANGE** to advance the remote access code number by 10.

Number of messages waiting
(or, during playback, message
number currently playing)



Press **PLAY/STOP** to begin or
end message playback

- 1**  **(Play/Stop)**
 "You have [xx] new
and [xx] old messages"

Message playback begins. See
options at right.

- 2**  **(Play/Stop)**

Message playback ends.

i **NOTE:** If "F" is flashing in
the message window, memory is
full. You will have to delete some
messages before new ones can
be received.

i **NOTE:** New (unheard)
messages cannot be deleted.

Answering System Operation

Message playback

Press **PLAY/STOP** to hear messages. The system
announces the number of messages, then begins playback.

If you have new messages waiting, you will hear only the
new messages (oldest first). If there are no new messages,
the system will play back all messages (oldest first).

Announcements

- When playback begins, you will hear the total
number of messages.
- Before each message, you will hear the day and time
it was received.
- After the last message, you will hear "End of messages."
If the system has less than 5 minutes of recording
time left, you will hear time remaining.

Options during playback

- Press **VOLUME** button to adjust speaker volume.
- Press **SKIP** to skip to next message (or hold down to
speed up message playback).
- Press **REPEAT** to repeat message currently playing.
Press twice to hear previous message. (Hold down
to slow message playback).
- Press **DELETE** to delete message being played back.
- Press **PLAY/STOP** to stop playback.

To delete all messages

To delete all messages, press and hold **DELETE** while
the phone is idle (not during a call, or during message
playback).

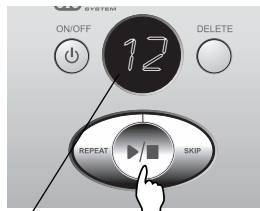

Elapsed recording time (seconds) Press to stop recording

1 **RECORD**
 "Now recording..."

2 Speak into microphone



Microphone ↑

3 **(Play/Stop)**
 Beep (Memo has been recorded)

Answering System Operation

Recording and playing memos

Memos are messages you record yourself. They are saved, played back and deleted exactly like incoming messages. You can record a memo as a reminder to yourself, or leave a message for someone else if others in your household use the answering system.

To record a memo

Follow the steps at left to record a memo. Elapsed time (in seconds) are shown in the message window as you record. You can record a memo up to 4 minutes long. Memos less than 1 second long will not be recorded.

To play back a memo

Press **PLAY/STOP** to hear messages and memos (see page 40 for other options).



Message window

Answering System Operation

Message window displays

The message window usually displays the total number of memos and incoming messages. See list below for explanation of other displays in this window.

Message window displays

□	No messages waiting.
1-99	Number of messages/memos, or message currently playing (see page 40).
10-99	Current Remote Access Code while setting (see page 39).
1-8	Current volume level while adjusting
1-99 (counting)	Elapsed time while recording a memo (see page 41) or announcement up to 90 seconds (page 37).
99 (flashing)	Memo recording exceeded maximum time of 99 seconds.
F (flashing)	Memory is full. Messages must be deleted before new messages can be received.
CL (flashing)	Clock needs to be set (see page 36).
A	Announce Only mode is on (see page 38).
--	System is answering a call, or being accessed remotely.
-- (flashing)	System is being programmed or initialized.
□n (or) □F	Displayed for 1 second when any answering system setting is turned on or off.

- 1** Dial your telephone number from any touch-tone phone
- 2** When system answers, enter 2-digit Remote Access Code ("19" unless you have changed it)
- 3** Enter remote commands (see list at right)
- 4** Hang up to end call and save all undeleted messages

Answering System Operation

Remote access

A 2-digit security code is required to access your answering system from any touch-tone phone. This code is "19" by default; see page 39 to change it.

Play messages # 2	Press to hear new messages (if none are new, all play back).
Repeat or go back # 4	Press to repeat current message. Press twice (# 4 # 4) to hear previous message.
Skip to next message # 6	Press to skip current message and advance to next message.
Stop # 5	Press to stop any operation (stop playback, stop recording).
Delete message # 9	Press during playback to delete current message.
Review announcement # 7	Press to review current outgoing announcement.
Record announcement * 7 to begin recording # 5 to stop recording	Press * 7, wait for beep, then begin speaking. Press # 5 to stop recording and hear playback of new announcement.
Record memo * 8 to begin recording # 5 to stop recording	Press * 8, wait for beep, then begin speaking. Press # 5 to stop recording.
Turn system off # 0	Press to turn off answering system. Incoming calls will no longer be answered.
Turn system on # 0	If off, system will answer after 10 rings. Enter your access code, then press # 0 to turn on.
Help Menu # 1	Press to hear list of features & commands.
Exit * 0	End remote access call (or hang up).







i **NOTE:** If you pause for more than 10 seconds during remote access, you will hear a help menu listing all features & commands. If you issue no command for another 20 seconds, the call will end automatically.

Appendix

Display screen status icons





Handset status icons





-  Phone in use (external call)
-  Parallel set in use (non-system)
-  Phone in use (intercom call); flashes when handset is being paged
-  Battery power level (see below); animated display when charging
-  Ringer off
-  Answering system is receiving an incoming call
- 1** Phone in use (external or intercom call); 1-8 = handsets, 0 = base
- M** Microphone is muted
- H** Call is on hold
- 1** Current handset identification.
- !** Handset is not yet registered, or searching for base



Base status icons

-  Spare battery charging
-  Ringer off

Battery power levels





-  Battery fully charged
-  Approximately half power remaining
-  Battery power is low; should be recharged soon
-  (flashing) Battery power is very low and must be recharged

Appendix

Alert tones and indicator lights



Alert tones

	"Beep-Beep-Beep-Beep" (5 quick beeps)	Handset battery is low. Place handset in base to charge the battery.
	Confirmation tone ("Happy" tone)	Handset registration or programming command successfully completed.
	Out of Range tone (multiple beeps at 1-second intervals)	The handset is out of range. Move closer to the base.
	"Beeeeeeeeeep" (1 long beep)	Error tone (current operation has been unsuccessful; try again).

Indicator lights

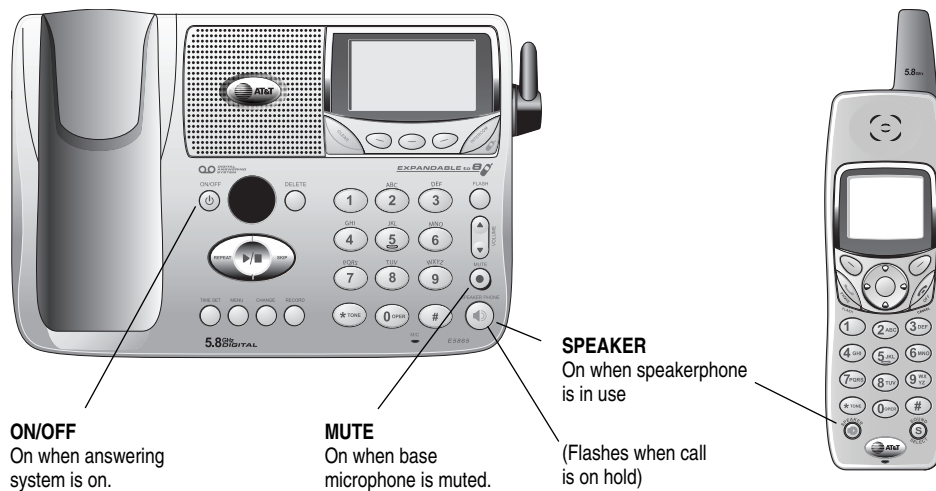

Appendix

Adding new handsets

Your telephone can accommodate up to 8 cordless handsets. You can add new handsets (sold separately) at any time. Up to 4 handsets at a time can be used.

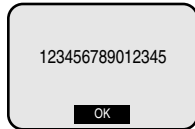
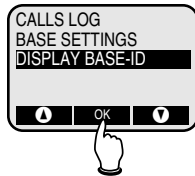
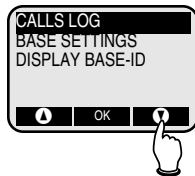
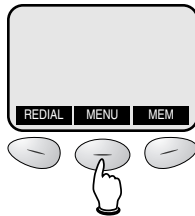

Before using a new handset, you must register it with the base. During registration, you must enter the 15-digit ID number of the telephone base. To find this number, go to the base, press **MENU**, scroll down to select **DISPLAY BASE ID**, then press **OK**.

Follow the instructions provided with your new handset to register it for use with your telephone.

The handset provided with your telephone is automatically registered as Handset 1. Additional handsets will be assigned numbers in the order they are registered (2, 3, 4, etc.) up to a maximum of eight handsets.



Handset 1



Handset 2



Handset 3



Appendix

Charging spare batteries

Optional spare batteries (sold separately) can be kept charged in the base, for quick replacement when handset batteries become depleted.

In the event of a power failure, the charged batteries in the base will allow you to make and receive calls from the cordless handset for up to 2.5 hours.

Spare batteries require at least 20 hours to reach full charge.



Slide latch left to open battery drawer

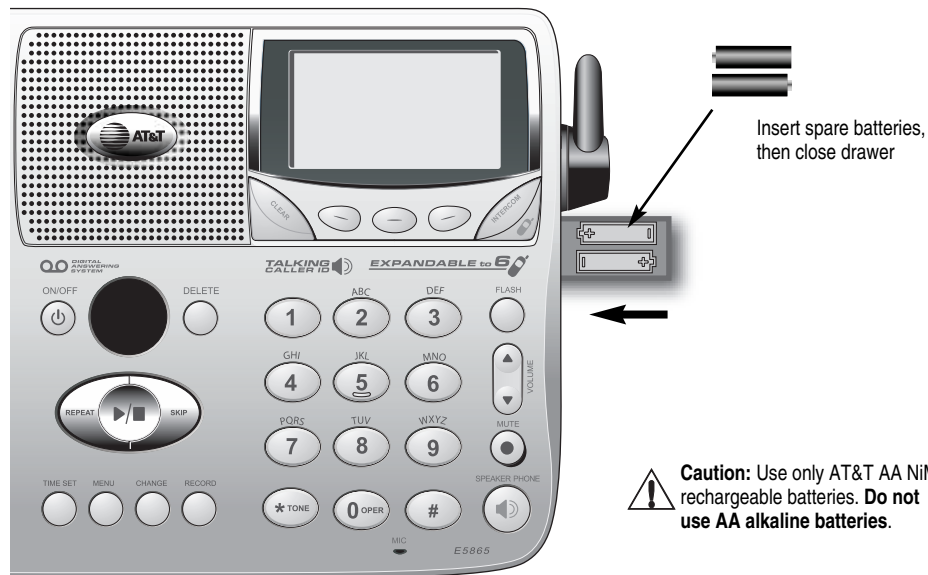

*Appendix***In case of difficulty**

If you have difficulty with your phone, please try the suggestions below. For Customer Service, visit our web site at www.telephones.att.com, or call 1 800 222-3111.

Telephone does not work at all

- Make sure batteries are installed and charged correctly (see page 7).
- Make sure the AC adapter is plugged into an outlet not controlled by a wall switch.
- Make sure the telephone line cord is plugged firmly into the base unit and the modular jack.
- Make sure the base antenna is fully upright.
- If you have dial pulse telephone service, make sure the dial mode is set to dial pulse (see page 17).
- If these suggestions do not work, unplug the base, remove and re-insert the batteries, then place the handset in the base to re-initialize.

Phone does not ring

- Make sure the ringer is on (see page 15).
- Make sure the telephone line cord and AC adapter are plugged in properly (see page 6).
- Make sure the base antenna is fully upright.
- Move the handset closer to the base.
- You might have too many extension phones on your telephone line to allow all of them to ring. Try unplugging some of them.

If you hear noise or interference during a call

- Make sure the base antenna is fully upright.
- You may be out of range. Move closer to the base.
- Appliances plugged into the same circuit as the base can cause interference. Try moving the appliance or base to another outlet.
- The layout of your home or office might be limiting the operating range. Try moving the base to another location, preferably on an upper floor.
- If the buttons don't work, try placing the handset in the base for at least 15 seconds.
- Disconnect the base from the modular jack and plug in a corded telephone. If calls are still not clear, the problem is probably in your wiring or local service. Call your local telephone service company.

Appendix

In case of difficulty

If you lose a call after changing channels

- You were probably almost out of range. Move closer to the base before changing channels. Before placing another call, set the handset in the base for at least 15 seconds.

Incomplete messages

- If a caller leaves a very long message, part of it may be lost when the system disconnects the call after 4 minutes.
- If the caller pauses for more than 7 seconds, the system stops recording and disconnects the call.
- If the system's memory becomes full during a message, the system stops recording and disconnects the call.

Difficulty hearing messages

- Press  to increase speaker volume.

System does not answer after correct number of rings

- Make sure that the answering system is on.
- If Toll Saver is activated, the number of rings changes to 2 when you have new messages waiting (see page 39).
- In some cases, the system may be affected by the ringing system used by the local telephone company.
- If the memory is full or the system is off, the system will answer after 10 rings.

"CL" flashes in message window

- You need to reset the answering system clock (see page 36).

System does not respond to remote commands

- Make sure to enter your Remote Access Code correctly (see page 43).
- Make sure you are calling from a touch-tone phone. When you dial a number, you should hear tones. If you hear clicks, the phone is not a touch-tone telephone and cannot activate the answering system.
- The answering system may not detect the Remote Access Code while your announcement is playing. Try waiting until the announcement is over before entering the code.
- There may be noise or interference on the phone line you are using. Press dial-pad buttons firmly.

Announcement message is not clear

- When you record your announcement, make sure you speak in a normal tone of voice, about 9 inches from the base.
- Make sure there is no "background" noise (TV, music, etc.) while you are recording.

Appendix

Index**A**

AC adapter, 6
Access code, 39, 43
Alert tones, 45
Answering calls, 10, 11
Answering system, 35
 announce only, 38
 delete messages, 40, 43
 feature options, 39
 handset access, 27
 outgoing announcement, 37, 43
 memos, 41
 message window, 42
 play messages, 40, 43
 remote access, 43
 remote access code, 39, 43
Antenna, 7

B

Battery charging, 7, 47
Battery installation, 7
Belt clip, 9

C

Call logs, 26, 31
Caller ID, 5, 28, 32
 add entries to phone directory, 28, 32
 delete entries, 28, 32
 dial entries, 29, 33
Call screening, 39
Call waiting, 5, 12
CID, 28, 32
Conference calls, 12

D

Day/time, 36
Delete Call Log entries, 28, 32
Delete redial entries, 30, 34
Dialing,
 manual dialing, 10, 11
 phonebook dialing, 21, 25
Display screen, 44
Distinctive ring, 18

E

Elapsed time, 37, 41
Ending calls, 10, 11
Error tones, 45

F

Flash (switchhook flash), 12

H

Hands-free use, 10
Headphone, 9
Hold, 10, 11

I

Incoming call log, 28, 32
Incoming calls, answering, 10, 11, 13
Incoming messages, 35
Indicator lights, 45
Intercom, 13

L

Last number redial, 30, 34
Low battery, 7

M

Making calls, 10, 11
Memos, 41
Menus, 2, 14-17
Message alert, 39
Messages, 35-43
Microphone, 37, 41
Missed calls, 28, 32
Mute, 10, 11

Appendix

Index**N**

Names,
 enter into phonebook, 19, 23
 search for, 20, 24
New handsets, 46
Number of rings before answer, 39

O

On/off button, 35
Operating range, 5
Outgoing announcement, 37, 43
Out of range, 5

P

Paging, 13
Phonebooks,
 base phonebook, 22
 handset phonebook, 18
 dial number, 21, 25
 edit entries, 21, 25
 name search, 20, 24
 new entries, 19, 23
Pictures, 14
Playback (messages), 40
Problems, 48

Q

Quick reference guide, 2-3

R

Receiving calls, 10, 11
Recharging, 7, 47
Redial, 30, 34
Repeat, 40
Ring silencing, 12
Ring tone options, 15, 17

S

Search for name, 20, 24
Security codes, 39, 43
Skip, 40
Sounds & alerts, 15, 45
Spare batteries, 47
Speakerphone, 10, 11

T

Technical specifications, 52
Time, 36
Timers,
 recording announcement, 37
 recording memo, 41
Tones,
 base tones & alerts, 17
 handset tones & alerts, 15
 send tones during call, 12
Troubleshooting, 48

V

Voice mail, 27, 35
Volume controls, 12

*Appendix***Technical specifications**

RF Frequency Band (Handset to Base)	2400 MHz — 2483.5 MHz
RF Frequency Band (Base to Handset)	5725 MHz — 5850 MHz
Channels	95
Channel Spacing	864 KHz
Sensitivity	-93 dBm
Base Unit Voltage (AC Voltage, 60Hz)	96 — 127 Vrms
Base Unit Voltage (AC Adapter Output)	7 Vdc @1A
Handset Voltage	2.4 Vdc (2 x AA NiMH 1400mAh batteries)

Appendix

Remote access wallet card

Your package includes a handy wallet card to help you remember access commands you can use to control your answering system from any touch-tone telephone.

If you misplace this card, just clip and save the card below.

Cut along dotted line



Call your phone number, then enter your 2-digit access code (preset to 19).

Action	Remote Command
Voice help menu	# 1
Play messages	# 2
Repeat message	# 4
Skip message	# 6
Stop	# 5
Save messages	Hang up
Delete message	# 9 while message plays

Fold here

Review announcement	# 7	
Record announcement	* 7	Speak after beep
	# 5	to stop
Record memo	* 8	Speak after prompt
	# 5	to stop
End remote access call	* 0	(or hang up)
Turn system off	# 0	(enter again to turn on)
Turn system on	If off, system answers after 10 rings. Enter your access code, then press # 0 to turn system on.	

5.8 GHz Cordless Speakerphone/Answering System E5865



www.telephones.att.com

Copyright © 2004 Advanced American Telephones. All Rights Reserved.
AT&T and the Globe Design are trademarks of AT&T Corporation,
licensed to Advanced American Telephones. Printed in China. Issue 1.5 AT&T 01/03/04.



5.8" (14.7 cm)



FLASH

CANCEL



1

2 ABC

3 DEF

4 GHI

5 JKL

6 MNO

7 PQRS

8 TUV

9 WXYZ

* TONE

0 OVER

#





User Manual (Part 2)

5.8 GHz Expansion Handset E580-I

**For use with AT&T models
E5860 • E5865 • E5900B • E5965C**



**You must charge
batteries and register the
handset before use.**



**See pages 2-3
for easy instructions.**

For customer service or product
information, visit our web site at
www.telephones.att.com
or call **1-800-222-3111**.

Please also read
Important Product Information
Enclosed in product package.

Table of contents

Before you begin.....	1
Parts checklist.....	1
Battery installation & charging.....	2
Registering the handset.....	3
Belt clip & optional headset.....	4
Quick reference guide.....	5

Before you begin

This cordless telephone operates with the maximum power allowed by the Federal Communications Commission (FCC). Even so, the handset and base can communicate over only a certain distance — which can vary with the locations of the base and handset, the weather, and the construction of your home or office. For best performance, keep the base antenna fully upright.

If you receive a call while you are out of range, the handset might not ring — or if it does ring, the call might not connect when you press **PHONE**. Move closer to the base, then press **PHONE** to answer the call.

If you move out of range during a phone conversation, you might hear noise or interference. To improve reception, move closer to the base.

If you move out of range without pressing OFF, your phone will be left “off the hook.” To hang up properly, walk back toward the telephone base, periodically pressing **OFF** until the call is disconnected.

Parts checklist

Remember to save your sales receipt and original packaging in case you ever need to ship your telephone for warranty service. Check to make sure the telephone package includes the following:

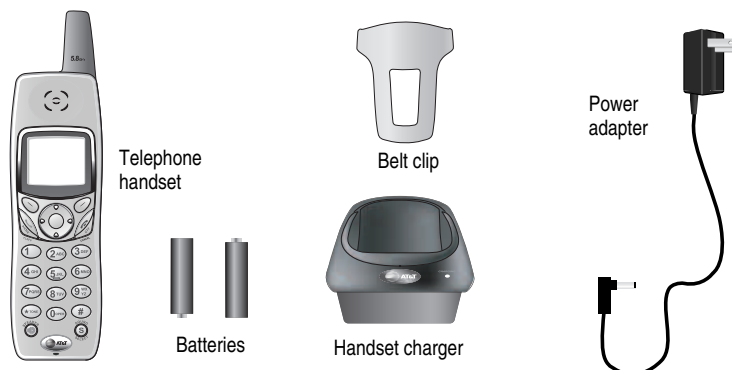

Battery installation & charging

After installation, place the handset in the charger and allow batteries to charge for 12 hours before use. You can keep batteries charged by returning the handset to the charger after each use. When battery power is fully depleted, a full recharge takes about 8 hours.

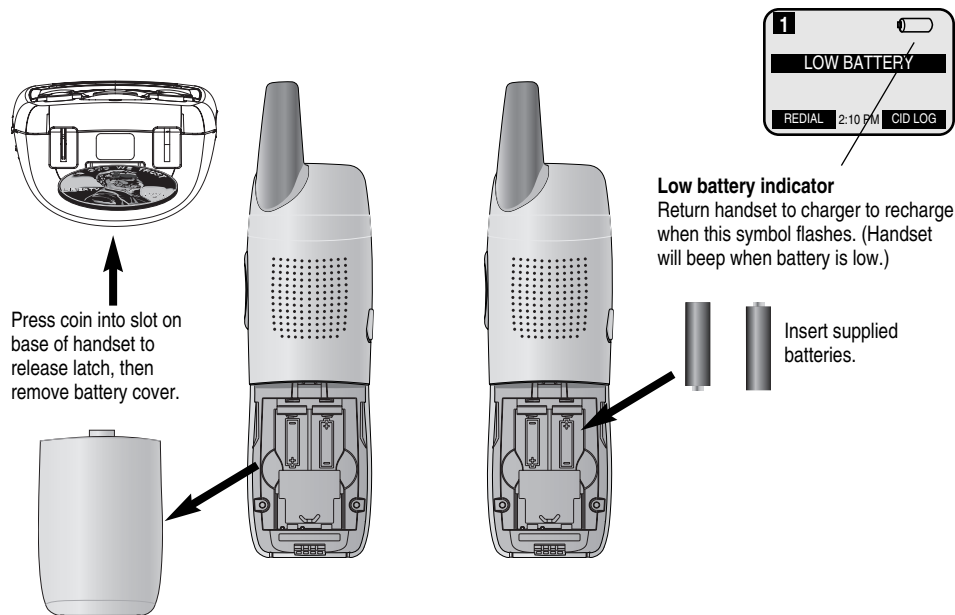

To replace battery cover

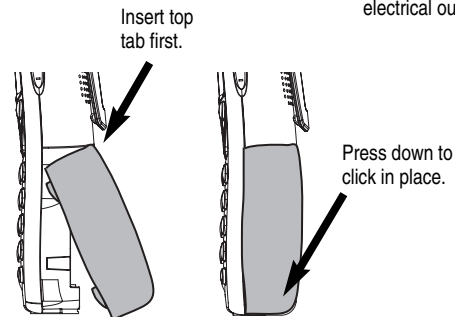

Caution: Use only the supplied NiMH battery (80-5461-00-00) or AT&T model 2AA NiMH replacement battery (SKU 26820). **Do not use alkaline batteries.**

Plug power cord into jack on underside of charger, then plug transformer into electrical outlet.

Place handset in charger to charge for 12 hours before first use.

Light remains on while batteries are charging.

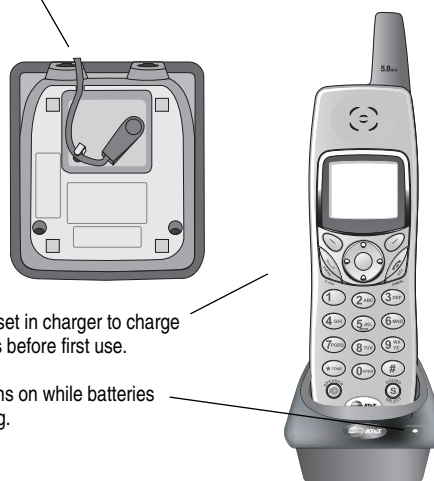

Registering the handset

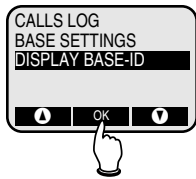
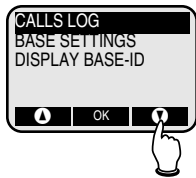
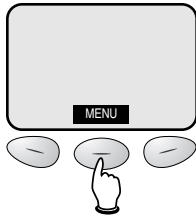

Before using your new handset, you must register it with the base. During registration, you must enter the 15-digit ID number of the telephone base. To find this number, go to the base, press **MENU**, scroll down to select **DISPLAY BASE ID**, then press **OK**.

The handset provided with your telephone is automatically registered as Handset 1. Additional handsets will be assigned numbers in the order they are registered (2, 3, 4, etc.) up to a maximum of eight.



Handset 1



Handset 2



Handset 3



Belt clip & optional headset

Install belt clip as shown below if desired.

For hands-free telephone conversations, you can use any industry standard 2.5 mm headset (purchased separately). For best results use an AT&T 2.5 mm headset.

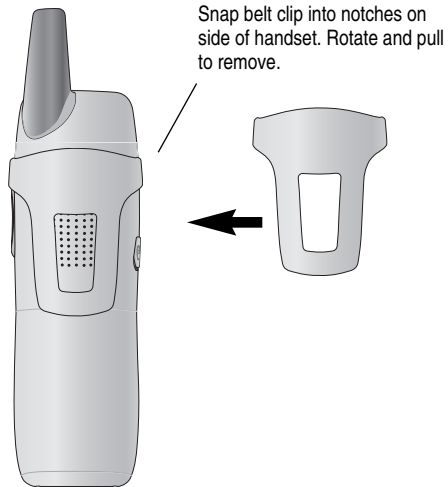

Quick reference guide

For complete instructions, please refer to the manual provided with your telephone.

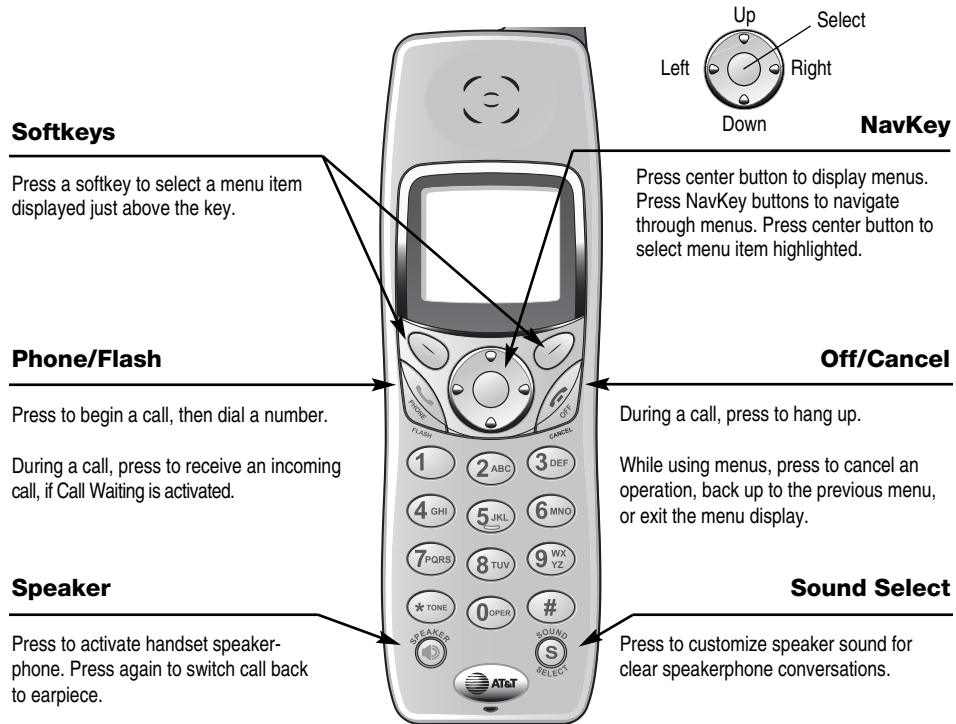

Main menu

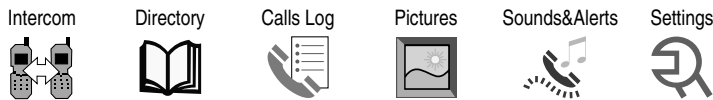

Sounds & Alerts menu

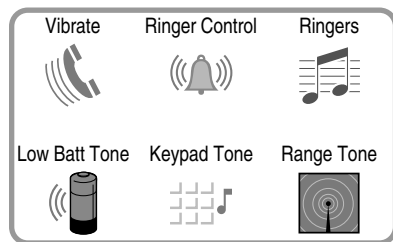

Settings menu

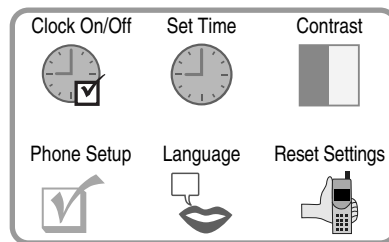



www.telephones.att.com

5.8" (14.7 cm)



FLASH

CANCEL





User Manual (Part 2)

5.8 GHz Expansion Handset E580-2

**For use with AT&T models
E5860 • E5865 • E5900B • E5965C**



**You must charge
batteries and register the
handset before use.**



**See pages 2-3
for easy instructions.**

For customer service or product
information, visit our web site at
www.telephones.att.com
or call **1-800-222-3111**.

Please also read
Important Product Information
Enclosed in product package.

Table of contents

Before you begin.....	1
Parts checklist.....	1
Battery installation & charging.....	2
Registering the handset.....	3
Belt clip & optional headset.....	4
Quick reference guide.....	5

Before you begin

This cordless telephone operates with the maximum power allowed by the Federal Communications Commission (FCC). Even so, the handset and base can communicate over only a certain distance — which can vary with the locations of the base and handset, the weather, and the construction of your home or office. For best performance, keep the base antenna fully upright.

If you receive a call while you are out of range, the handset might not ring — or if it does ring, the call might not connect when you press **PHONE**. Move closer to the base, then press **PHONE** to answer the call.

If you move out of range during a phone conversation, you might hear noise or interference. To improve reception, move closer to the base.

If you move out of range without pressing OFF, your phone will be left “off the hook.” To hang up properly, walk back toward the telephone base, periodically pressing **OFF** until the call is disconnected.

Parts checklist

Remember to save your sales receipt and original packaging in case you ever need to ship your telephone for warranty service. Check to make sure the telephone package includes the following:

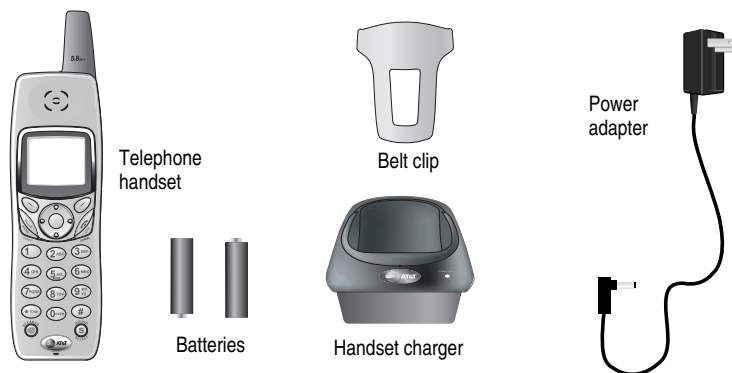

Battery installation & charging

After installation, place the handset in the charger and allow batteries to charge for 12 hours before use. You can keep batteries charged by returning the handset to the charger after each use. When battery power is fully depleted, a full recharge takes about 8 hours.

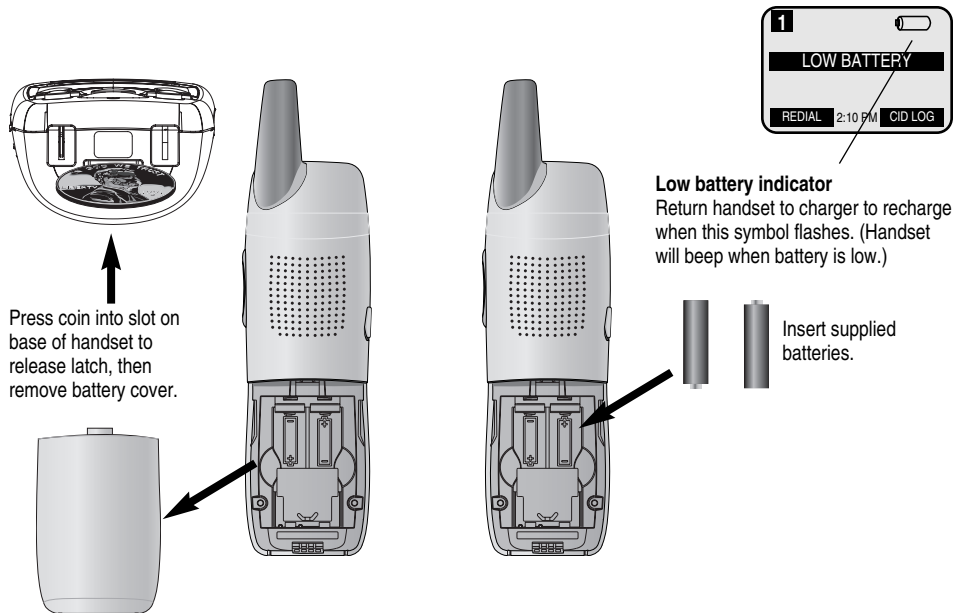

To replace battery cover

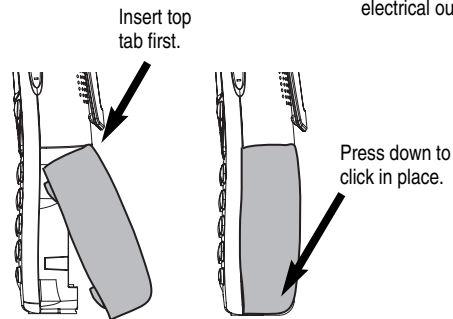

Plug power cord into jack on underside of charger, then plug transformer into electrical outlet.

Caution: Use only the supplied NiMH battery (80-5461-00-00) or AT&T model 2AA NiMH replacement battery (SKU 26820). **Do not use alkaline batteries.**

Place handset in charger to charge for 12 hours before first use.

Light remains on while batteries are charging.

Registering the handset

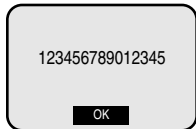
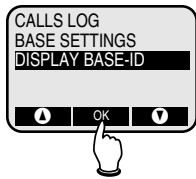
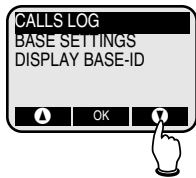
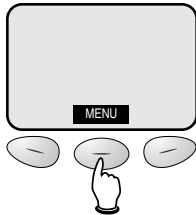

Before using your new handset, you must register it with the base. During registration, you must enter the 15-digit ID number of the telephone base. To find this number, go to the base, press **MENU**, scroll down to select **DISPLAY BASE ID**, then press **OK**.

The handset provided with your telephone is automatically registered as Handset 1. Additional handsets will be assigned numbers in the order they are registered (2, 3, 4, etc.) up to a maximum of eight.



Handset 1



Handset 2



Handset 3



Belt clip & optional headset

Install belt clip as shown below if desired.

For hands-free telephone conversations, you can use any industry standard 2.5 mm headset (purchased separately). For best results use an AT&T 2.5 mm headset.

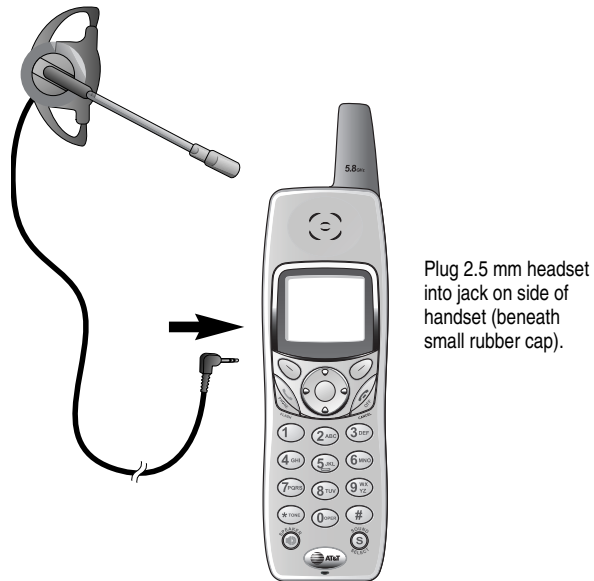
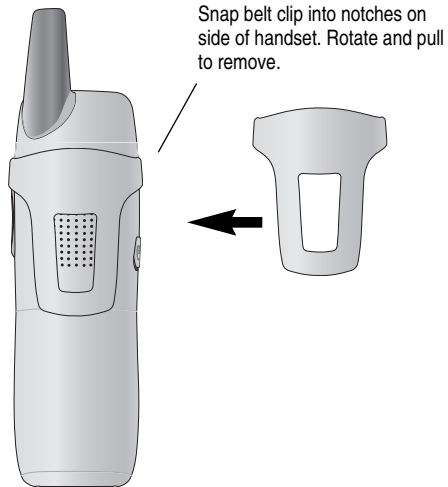

Quick reference guide

For complete instructions, please refer to the manual provided with your telephone.

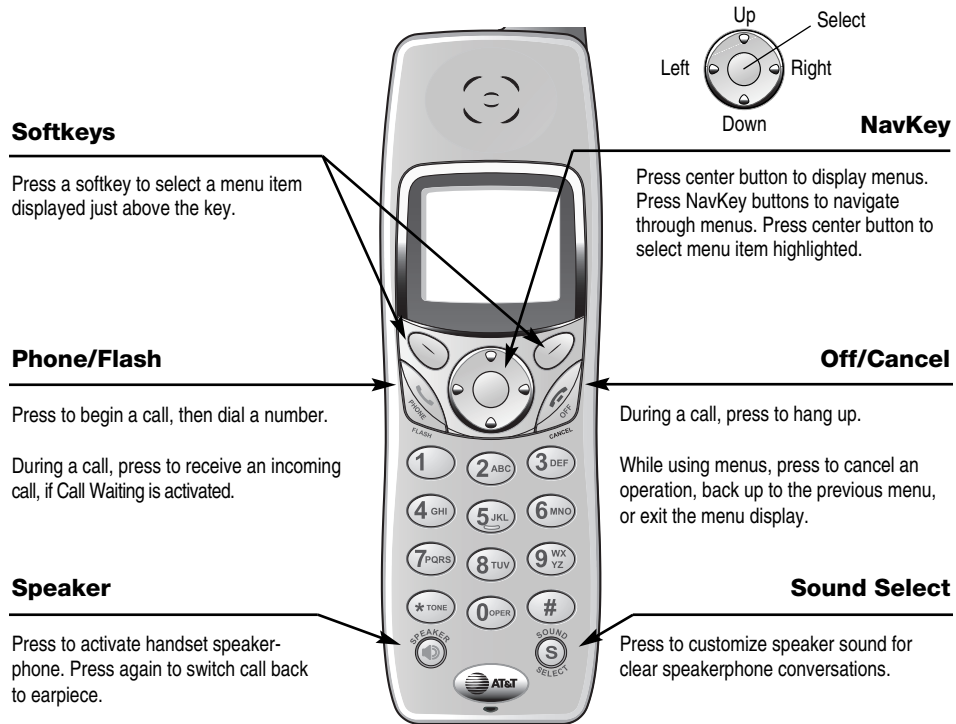

Main menu

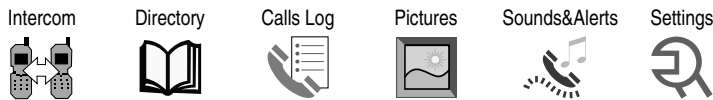

Sounds & Alerts menu

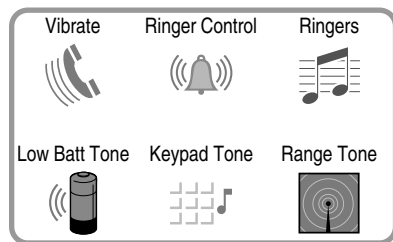

Settings menu

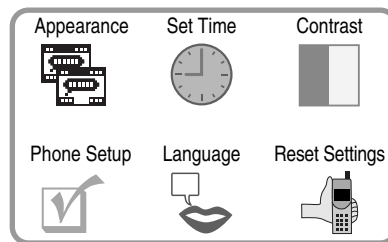



www.telephones.att.com

5.8" (148 mm)



FLASH

CANCEL

